

DIN 6923 ISO 4161

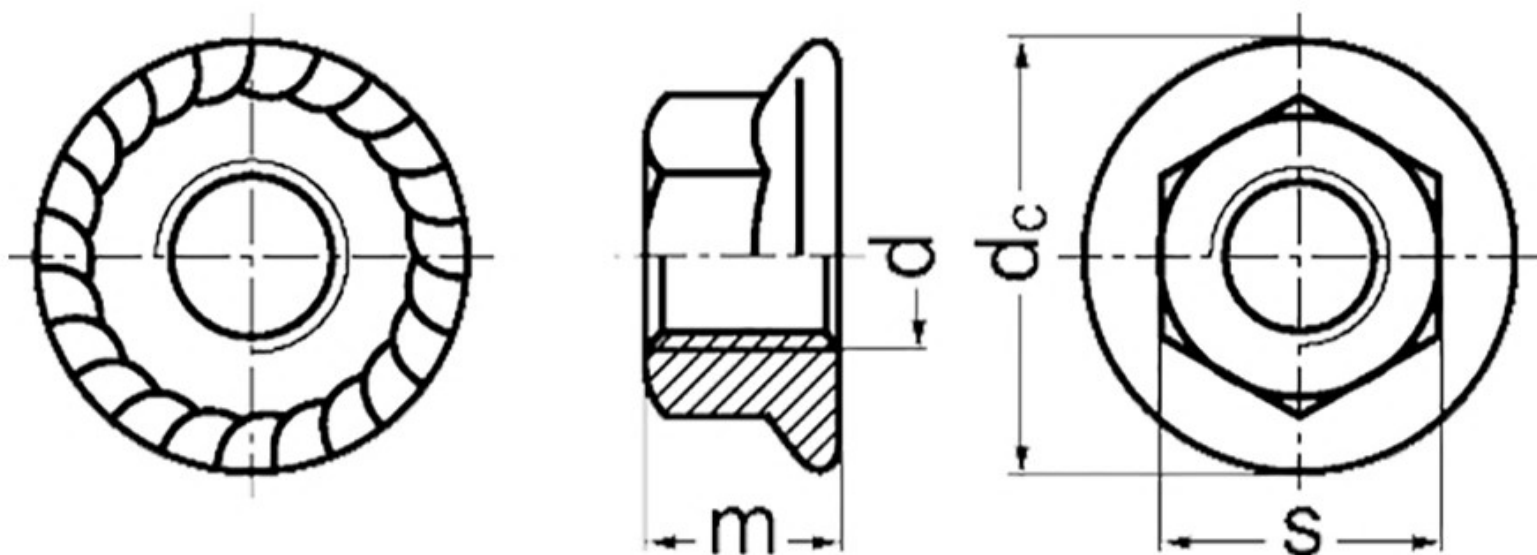

d	M3	M4	M5	M6	M8
p	0.5	0.7	0.8	1.0	1.25
dc max	8	10	11.8	14.2	17.9
s min	5.5	7	8	10	13
e	6.01	7.66	8.79	11.05	14.38
m max	4	4.5	5	6	8
d	M10	M12	M14	M16	M20
p	1.5	1.5/1.7 5	1.5/2.0	1.5/2.0	2.5
dc max	21.8	26	29.9	34.5	42.8
s min	15	18	21	24	30
e	16.64	20.03	23.36	26.75	32.95
m max	10	12	14	16	20