

Nylon Pan Head Screws

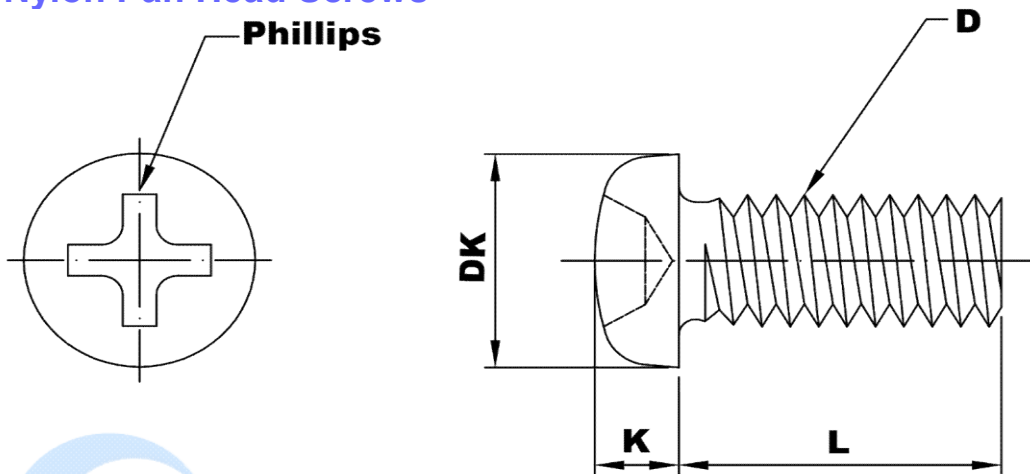

D	M2	M2.5	M3	M4	M5	M6	M8
Pitch	0.4	0.45	0.5	0.7	0.8	1	1.25
DK	3.3	4.1	5.3	6.6	8.5	10	13
K	1.3	2	2.2	2.4	2.9	4	4.5