

FH/FHS

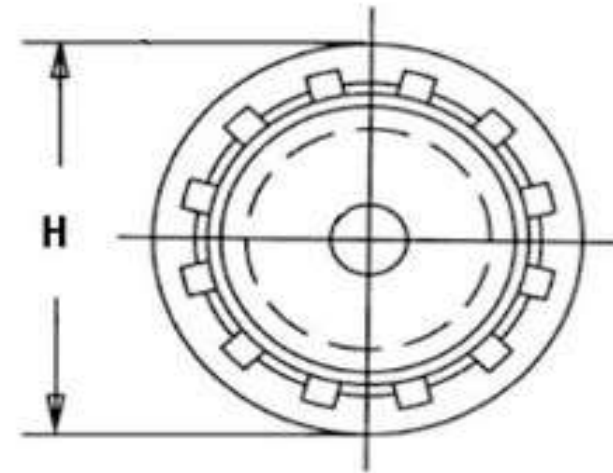
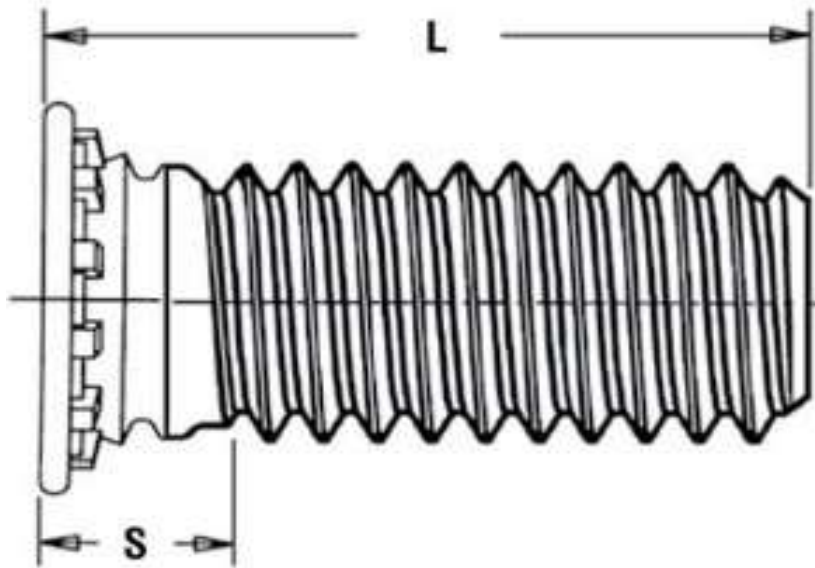

d	M2.5	M3	M3.5	M4	M5	M6	M8	
p	0.45	0.5	0.6	0.7	0.8	1.0	1.25	
H	4.1	4.6	5.3	5.9	6.5	8.2	9.6	
S max	1.95	2.1	2.25	2.4	2.7	3.0	3.7	

d	#2-56	#4-40	#6-32	#8-32	#10-24	#10-32	1/4-20	5/16-18
H	.144	.176	.206	.237	.256	.256	.337	.376
S max	.075	.085	.090	.090	.100	.100	.135	.160